

# PS522

# Assembly Guide

Version 1.00  
2022-12-31

nguyenkvn

# CONTENTS

Section 1: Introduction .....	3
Section II: Tools and Shopping List.....	4
Section III: Parts Kit Checklist .....	5
Receiver Parts.....	5
Magazines and Accessories .....	5
Section IV: Print Settings.....	6
Recommended Filament.....	6
Slicer Settings.....	6
Model Orientation .....	7
Section IV: Assembly .....	8
Safety first.....	8
Installing the barrel .....	9
Install the handguard shroud .....	10
Install the bolt and charging handle.....	11
Assemble the receivers .....	12
Function Check .....	14
Section V: Troubleshooting.....	15

# SECTION I: INTRODUCTION

The Sig Sauer 522, now mostly forgotten and long abandoned .22LR platform mimicking the look and feel of its bigger brother (the Sig Sauer 556), returns as the "Pond Side" 522 (PS522). The PS522 is easy to assemble and is particularly conservative on its use of plastic. It uses all original parts from the 522, except for the manual bolt-hold open.

The PS522 is another kit that occurred at happenstance. I was browsing EveryGunPart on occasion and saw this kit. Like some others I re-engineered, it had the hallmarks of a great candidate for re-engineering: simple moving bodies that could be accounted for in plastic, easy to measure (or approximate) shapes and assemblies, and a partially complete overall assembly.

The 522 takes common CMMG-style .22 LR conversion mags. (These are similar compatible magazines that are printable on the Gatalog, too.)

This is a particularly peculiar kit. It's a cadet rifle intended to mimic its larger centerfire sibling and will certainly garner similar curious inspections like the "real thing". This rifle has since been discontinued (made from 2009 to 2015) and was quite an uncommon find.

I hope you get to enjoy this resurrected collectible with my printed receiver, if you are fortunate enough to find a parts kit.

Vinh Nguyen

## SECTION II: TOOLS AND SHOPPING LIST

To assemble this firearm, you will **need** the following tools:

- Pliers
- Gunsmithing driver bit set

You can check out a recommended shopping list of tools Vinh keeps at his desk at [www.vinhstoolbox.com](http://www.vinhstoolbox.com).

## SECTION III: PARTS KIT CHECKLIST

In order to successfully build your PS522...

### RECEIVER PARTS

A complete upper assembly should compose of the following:

- Barrel Assembly
  - Is your barrel still attached to a severed upper receiver? You will need a spanner wrench (or a vice) to remove it.
- Bolt Assembly
- Bolt Charging Handle
- Handguard shroud
- False gas block
- False gas key (container)
- Iron sights (*optional*)
  - MFI LLC has a set of Sig Sauer 556/522 sights for sale.
- Assembled combined lower receiver (with the pins retained)
  - *This lower receiver should NEVER be disassembled. Putting it together is outside the scope of this guide.*

### MAGAZINES AND ACCESSORIES

Don't forget you will also need:

- Magazine
  - Any magazine using the CMMG .22 LR Conversion Magazine pattern will work.
  - Black Dog Machine .22 LR AR-15 Magazine
  - Sig Sauer .22 LR AR-15 Magazine
    - (*Actually a rebranded Black Dog Machine magazine.*)

# SECTION IV: PRINT SETTINGS

In this section, we will cover the settings for printing.

## RECOMMENDED FILAMENT

For printing the receiver, eSUN/Inland PLA+ is recommended. (It is the tested filament with this model.)

## SLICER SETTINGS

These are the required slicer settings for the receiver:

- Nozzle Size: 0.4mm
- Layer Height: 0.16mm
  - Initial Layer Height: 0.12mm
- Temperature: 220 C
- Wall Count: 6
- Infill: 100%
- Support: Enabled
  - Type: Tree
  - Placement: Touching Build Plate
- Adhesion Type: Brim

**ATTENTION:** It is imperative your z-step calibration is as precise as it can be. This model is very dependent on a proper z-axis calibration, and a model that has sandwiching or poor layer adhesion will not work properly.

## MODEL ORIENTATION

The model should be printed “muzzle end” down.

You must orient the model as pictured:

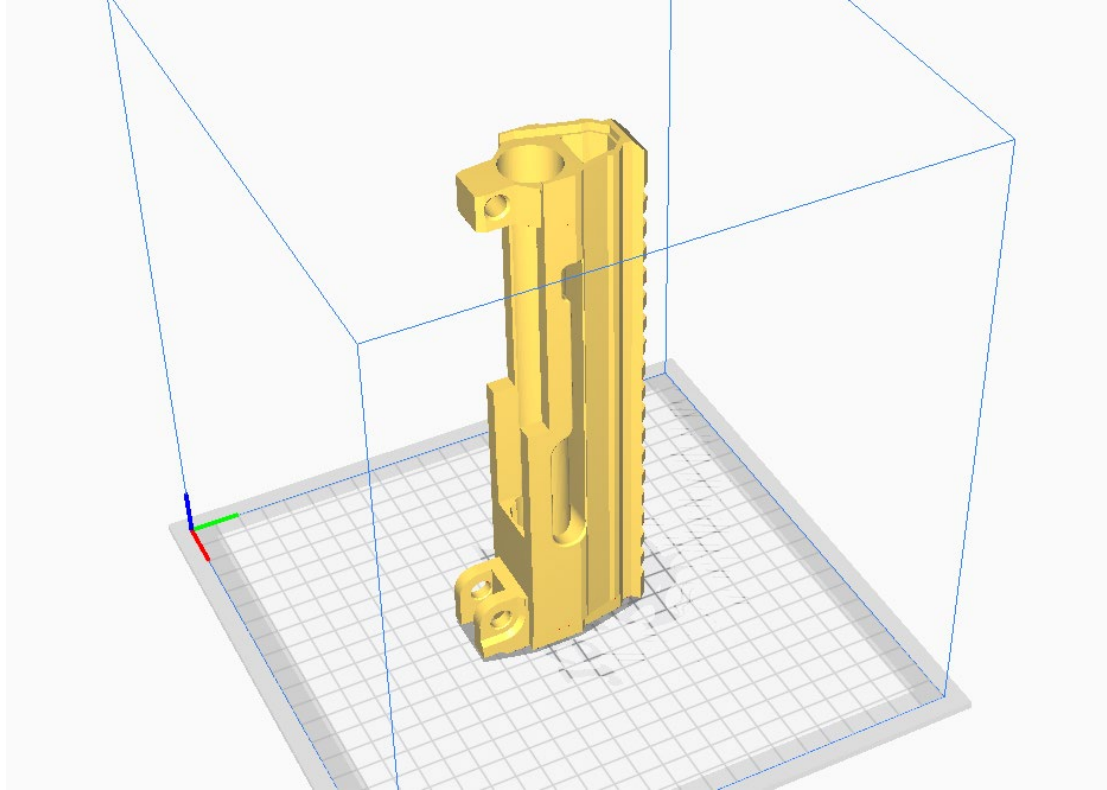

## SECTION IV: ASSEMBLY

In this section, we will cover the settings you should print your frame and assemble it.

### SAFETY FIRST

Putting a gun together is no joke. Firearms are dangerous tools that must be treated with care and respect. **You are responsible for your safety, and those surrounding you** when you work with or operate firearms. Fellow developers or engineers cannot be responsible or liable for what you do or don't do.

As a general reminder, here are some rules to keep in mind:

1. **Always treat a gun as if it is loaded.** Remove the magazine and check the chamber yourself to verify the gun is unloaded.
2. **Keep your firearm always pointed in a safe direction.** Never point your gun at anything you don't intend to destroy.
3. **Be aware of what is in front and behind of your target.**

But specifically, for working on your firearm, you should remember the following too:

1. **Keep live ammo away.** Use snap caps or dummy rounds to verify function of your firearm. Never keep live ammo around your workspace, and certainly never mix them with your dummy ammo.
2. **A clean gun is a safe gun.** Never leave your firearms uncared for to foul or dirty up. Debris can cause malfunctions, which can be dangerous.
3. **Always read and follow directions.** Don't ignore a warning or follow instructions out of order.
4. **Use prudent judgement.** If something doesn't add up- use common sense. Stop, inspect, and re-evaluate your previous actions and procedures.



## INSTALLING THE BARREL



Gently remove all support structures and debris from the print.



Insert the barrel.

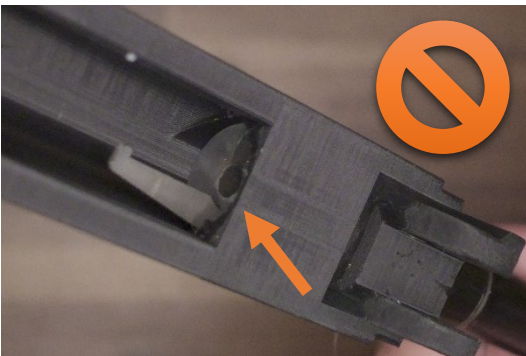

Ensure the breach face is flush to the internal breach face of the receiver.

This picture demonstrates an improperly installed barrel that has **not** been pushed in all the way.

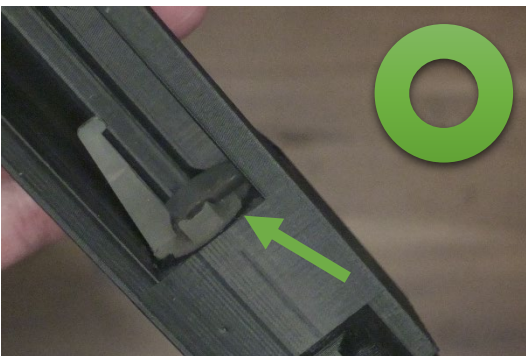

Ensure the breach face is flush to the internal breach face of the receiver.

This picture demonstrates a properly installed barrel that has been pushed in all the way.



**Install and thread the collar into the receiver.**

It will hold the barrel in place against the receiver.



**Do not force the collar.**

Simply ensure there is no play in the collar or the barrel.

## INSTALL THE HANDGUARD SHROUD

Before proceeding, now is the time to install the printed picatinny rail onto the upper shroud, if desired.



**Insert lower shroud first, then the upper shroud.**

Both parts should interconnect and lock by shifting the upper shroud towards the receiver while it is on top of the lower shroud.



**Attach the false gas block/shroud retainer to the barrel. Press it against the shroud.**



**Tighten the false gas block.**

## **INSTALL THE BOLT AND CHARGING HANDLE**



**Insert the bolt assembly partially into the upper. With the notch for the charging handle visible in the rear of the receiver, insert the charging handle.**



**Fully insert the bolt into the receiver.**

Ensure that the rear block is not canted.

The bolt should engage with the ejector, and slide parallel with it.



## ASSEMBLE THE RECEIVERS



**Attach the upper receiver to the lower receiver, starting with the front-most takedown pin.**



**Collapse the receivers together, and close the rear takedown pin.**



**Insert the false adjuster into the false gas-block.**

(It's a small storage container that can be used to store cleaning materials and such.)



**Attach the rear and front sights.**



**Assembly is complete.**

## FUNCTION CHECK

Verify your firearm works by evaluating each of the following functions.

### **BE SURE YOUR GUN IS STILL UNLOADED.**

**Check that your chamber is empty, and that there are no rounds in the magazine.**

- Empty Magazine Lock:
  - o Insert an empty magazine
  - o Pull the bolt back
  - o The bolt should be retained rearward.
  - o Remove the magazine
  - o Pull the bolt back
  - o The bolt should fall into battery.
- Trigger Reset
  - o Remove the magazine.
  - o Pull (and hold) the bolt back.
  - o Pull (and hold) the trigger.
  - o Release the bolt charging handle.
  - o Slowly release the trigger.
  - o The trigger should have a ever-so-quiet “click”, and a ever-so-perceptible tactile reset.

When you have completed the function check, the assembly process is complete.

Be sure to remove your magazine and store your firearm in a secure and safe place.

## SECTION V: TROUBLESHOOTING

You may encounter certain problems with your firearm either during usage or assembly.

- The receiver is too long or too short.
  - Check your printer z-steps for accuracy and reprint.